

SHURE**MICROPHONES AND ELECTRONIC COMPONENTS**

AREA CODE 312/328-9000 • CABLE SHUREMICRO

DATA SHEET**MODEL M65**
Stereo Preamplifier**STEREO CONVERSION PREAMPLIFIER**

GENERAL: The Shure M65 Stereo Conversion Preamplifier is designed to furnish the voltage gain and equalization necessary to operate magnetic phono cartridges (such as the Shure Dynetic Cartridges), and tape playback heads with standard audio amplifiers. One of the primary uses of the M65 is in the conversion of stereo systems converting from ceramic cartridges to magnetic cartridges. It can also be used without circuit modification as a preamplifier for microphones.

The M65 Stereo Preamplifier features a single rotary switch for selection of either phono, tape, microphone or a special function. The Phono function provides the Standard Equalization (RIAA) for phono records. This function is ideally suited as an input for amplifiers with a flat response. The Special function provides a compensated ceramic Equalization for phono records. This function is ideally suited for amplifiers normally used with Ceramic Phono cartridges. The preamplifier has two stages of amplification in each channel, providing STANDARD EQUALIZATION for tape (NARTB) and flat amplification for microphones.

A hum control (R_{20}) is provided and is pre-adjusted at the factory. If necessary, this control can be re-adjusted with a small screwdriver for minimum hum. For optimum results the system should use a 4-pole motor.

The input impedance is 47,000 ohms for all switch positions. If a higher impedance input is desired when used as a microphone preamplifier, the 47,000 ohm input resistor (R_1 or R_2) may be easily removed automatically raising the input impedance to approximately 250,000 ohms. If any circuit change is made, the power should be disconnected.

The output impedance is less than 5000 ohms in the "phono", "tape" and "special" functions allowing up to 75 feet (22.8m) of cable (30 pfd per foot [0.3m]) to be used without any high frequency losses.

The preamplifier has dual input and output jacks which will accept standard phono plugs. The preamplifier has its own power supply and is operated from 115-125 volt 60 cycle line power.

CAUTION: The use of the M65 Stereo Preamplifier with power amplifiers of the transformerless (AC-DC) type may be a shock hazard. A suitable power line isolation transformer should be used.

NOMINAL SPECIFICATIONS:

Gain: Phono 44db
(5 millivolts input produces .76 volts output)
Special 45db
(5 millivolts input produces .88 volts output)
Tape 40db
(5 millivolts input produces .50 volts output)
Microphone 63db
(2 millivolts input produces 2.8 volts output)

Frequency Response: ± 1.5 db of each function's nominal characteristic from 25 c.p.s. to 15,000 c.p.s.

Equalization:

Phono: RIAA equalization (with additional treble boost of approximately 3db at 10,000 c.p.s. to complement the high frequency characteristic of most magnetic cartridges.)

Special: A Shure developed magnetic phono Equalization circuit specially designed for use with high impedance amplifiers normally used with ceramic phono cartridges.

Tape: NARTB equalization.

Microphone: Flat response. ± 3 db from 20 c.p.s. to 12,000 c.p.s.

Input Impedance: 47,000 ohms (all functions).

Output Impedance: Low output impedance (less than 5000 ohms at 10,000 c.p.s. for phono, special and tape functions).

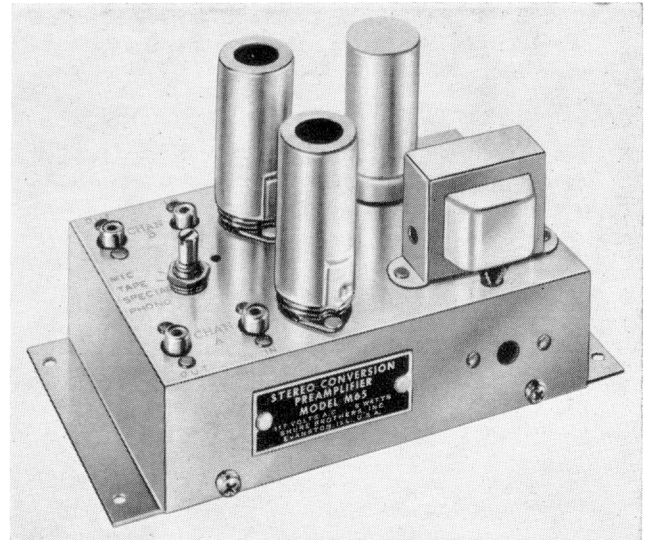

Channel Separation: 40db.

Channel Balance: ± 1 db at 1000 c.p.s.

Hum-Noise: 50db below rated output.

Tubes: Selected ECC83/12AX7.

Rectifier: Selenium.

Finish: Nickel Plate chassis.

Overall Dimensions: Length 6 $\frac{7}{8}$ " (174.6mm); Width 3 $\frac{1}{8}$ " (100.0mm); Height 3 $\frac{1}{4}$ " (95.2mm).

Power Consumption: 6 watts, 115-125 volts, 60 cycles.

INSTALLATION: The M65 Stereo Preamplifier may be mounted on an amplifier chassis or cabinet by using screws provided, or using #4 machine screws and #4 nuts through the 4 corner mounting holes provided in the preamplifier base. Amplifier can be mounted in any position for normal operation but should be located away from motors and other hum radiating power sources for best performance.

APPLICATIONS:

- Set selector switch to the desired function. Note that the screwdriver slot of the shaft should align with the desired function stamped on the chassis. This automatically selects the proper equalization or frequency response for both channels.
- For the Phono and Special positions, connect the signal leads from the phono cartridge to the jacks marked "IN" at "Channel A" and "Channel B". For the Tape position, connect the signal from the tape head to the jacks marked "IN" at "Channel A" and "Channel B". For the Microphone position using two separate microphones, connect the cable from one microphone to the jack marked "IN" at "Channel A". The cable from the other microphone should connect to the jack marked "IN" at "Channel B". For single microphone application, connect to either "Channel A" or "Channel B". Attention must be given to the information contained in the cartridge, tape head, or microphone data sheets regarding their connections, phasing and grounding.

- c. Connect the jacks marked "OUT" of "Channel A" and "Channel B" to the corresponding input jacks of the power amplifier. If it is found necessary to "ground" the M65 preamplifier chassis, a wire can be connected to one of the screws holding the bottom plate to the chassis.
- d. Insert the M65 power line cord in a 115-125 volt 60 cycle power outlet, preferably one controlled by the power amplifier's ON-OFF switch. In some applications, a lower hum level may be obtained by reversing the plug in the power socket.
- e. Further reduction in hum may be obtained by a re-adjustment of the hum control (R_{29}). The control is accessible for screwdriver adjustments thru a convenient side opening

located near the transformer. For hum adjustment, insert the screwdriver and rotate the control until the lowest audible level of hum is obtained from the speakers with no program material in the system and all control knobs set in the maximum position.

GUARANTEE: This Shure High Fidelity Component is guaranteed to be free from electrical and mechanical defects for a period of one year from date of shipment from factory, provided all instructions are complied with fully. In case of damage it is essential that you carefully repack the unit and return it to the factory for repair. Our guarantee is voided if the basic assembly has been opened or subjected to unreasonably rough handling.

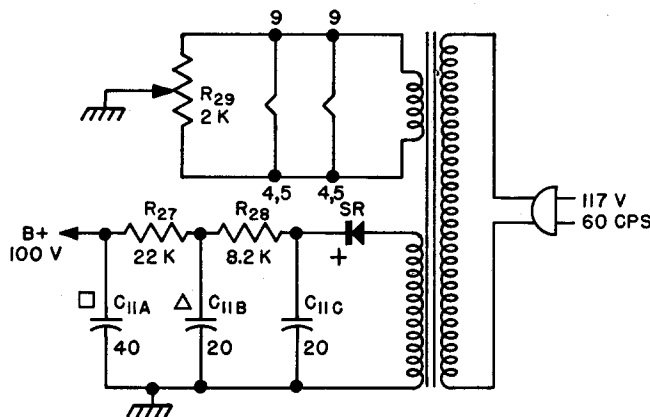
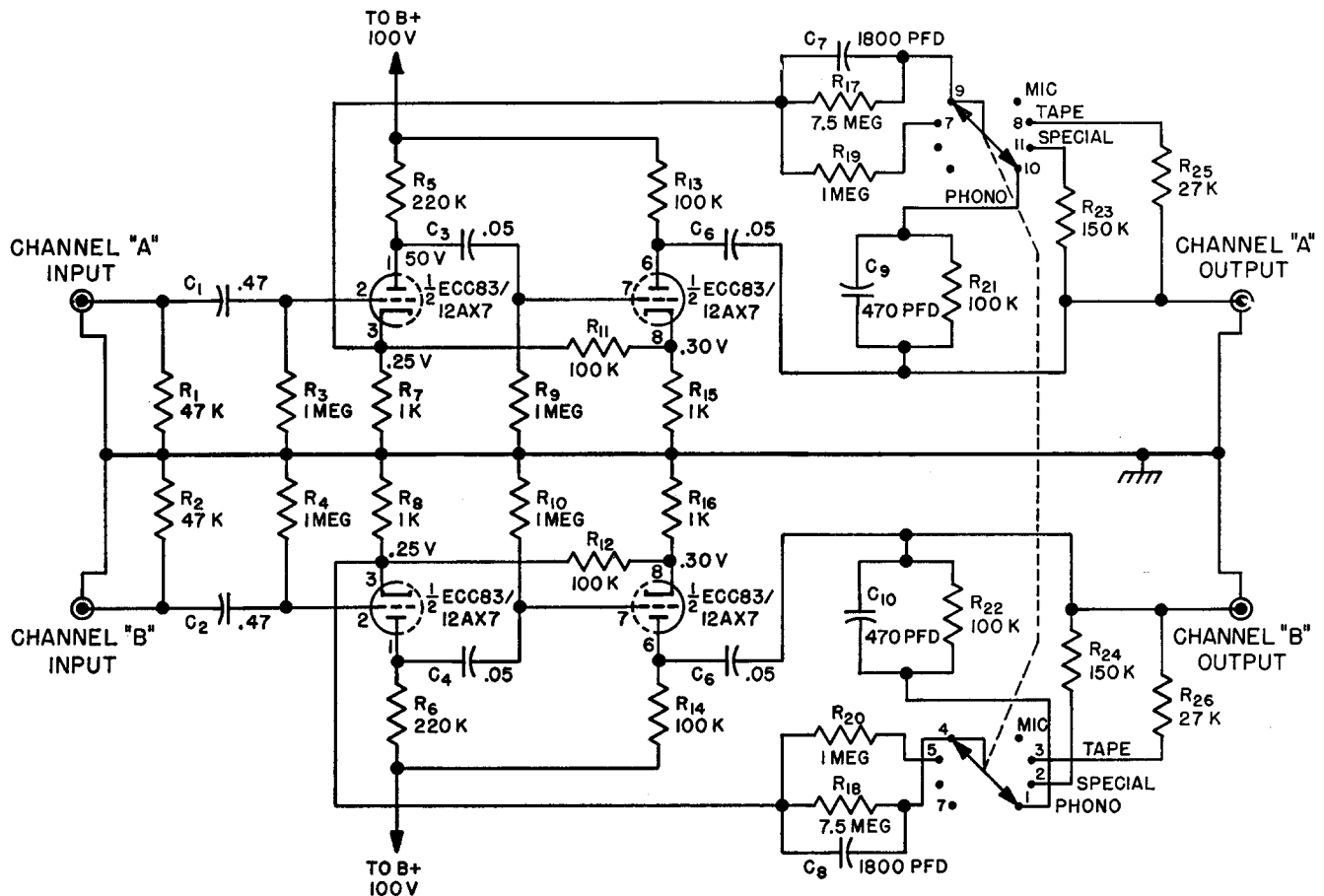

RESISTANCE IN OHMS:
K=1,000
MEG=1,000,000

RESISTORS— $\frac{1}{2}$ WATT, $\pm 10\%$
EXCEPT R_{17} AND R_{18} , $\pm 5\%$,
 R_{29} , 1 WATT, $\pm 20\%$ WIRE
WOUND POTENTIOMETER

CAPACITANCE IN MICROFARADS
EXCEPT C_7 , C_8 , C_9 , AND C_{10}
PFD= MICRO-MICROFARAD

SWITCH FUNCTIONS
CHANNEL "A" CHANNEL "B"
9-10—PHONO—4-1
9-11-7—SPECIAL—4-5-2
9-8—TAPE—4-3
MIC—4-7